

Figure 1.23 also shows the lateral contact modules with the following contact reference numbers, depending on whether they are assembled on the right-hand side or the left-hand side of the contactor unit.

For a lateral contact module assembled on the left:

- 13, 14 (normally open)
- 21, 22 (normally closed).

For a lateral contact module assembled on the right:

- 31, 32 (normally closed)
- 43, 44 (normally open).

It is unlikely that both the lateral and top mounted auxiliary contact modules would be used as an accessory for a single contactor basic unit, although this is a workable option.

Mechanical interlock

This is an accessory module that is integrated between two similar sized contactor basic units. The contactors are interlocked by using their magnetic systems linkage, preventing them from closing simultaneously. This mechanism is often used as an additional safety feature for electrically interlocked contactors.

Electrical interlock

This interlock consists of two normally closed auxiliary contacts that are interlinked with the

contactor coil circuits. While one contactor is energising, the normally closed contact 21/22 will open and prevent simultaneous occasional energising of the coil of the other contactor. This means that only one out of two interlocked contactors can be energised at any one time. Figure 1.25 shows an application diagram for an electrical interlock.

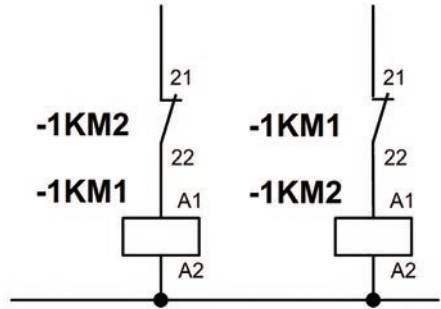

Figure 1.25 – Electrical interlock application diagram

Latching module

This module works in the same way as described in the relay section (1.1.2).

Time delayed contacts module

This module works in the same way as described in the relay section (1.1.2).

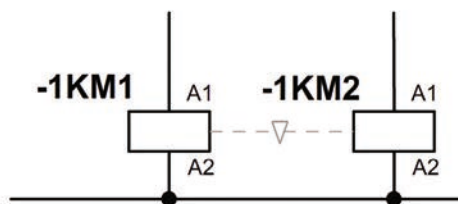
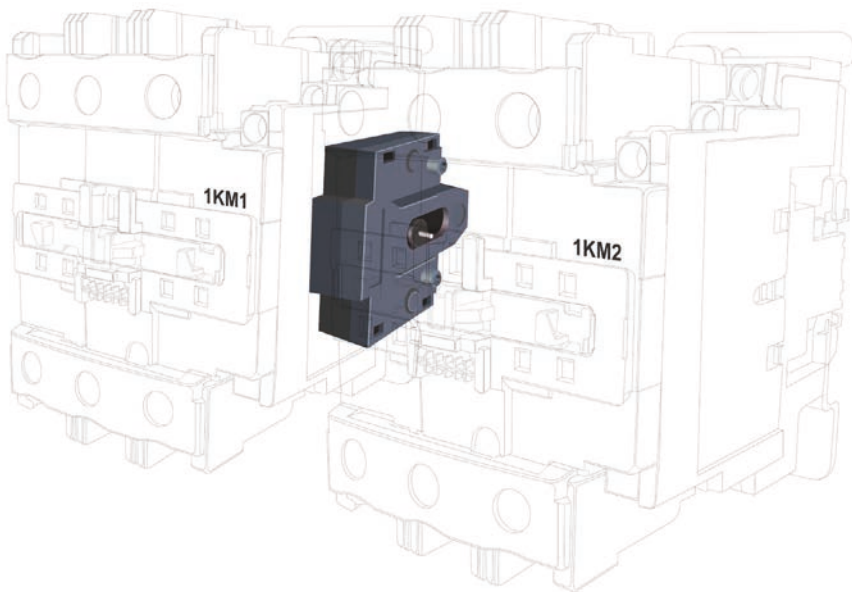

Figure 1.24 – Contactor's mechanical interlock
(Reproduced with kind permission from Schneider Electric)

1.1.5 Overload Relays

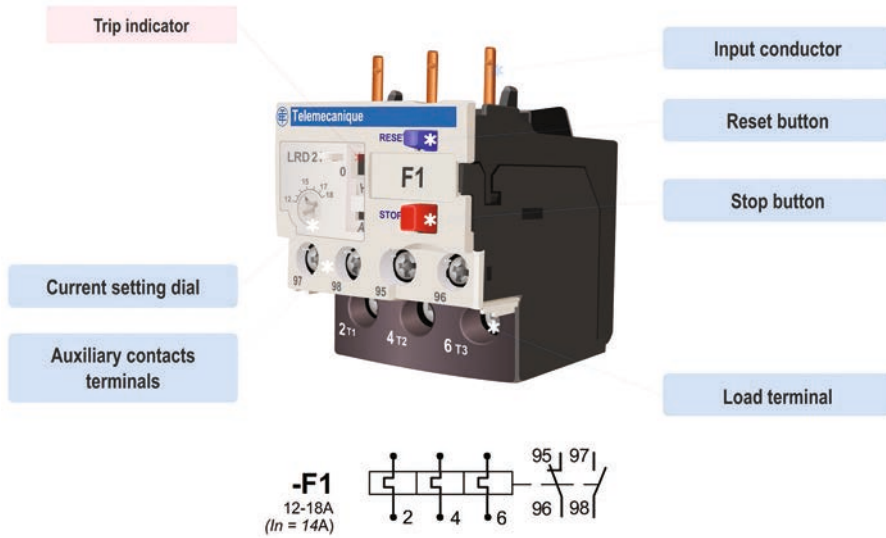

Figure 1.26 – Thermal overload relay
(Reproduced with kind permission from Schneider Electric)

Electrical overload can be a major problem for electric motors and starters circuits. Protection can be achieved by using a thermal overload relay that is integrated in series with the contactor's main contacts. This component is a small heater element that is wired in series with each phase of the motor

winding circuitry. A bi-metallic strip, situated in close proximity to the heater element, is used as a trip mechanism on auxiliary contacts:

- 95, 96 (normally closed)
- 97, 98 (normally open).

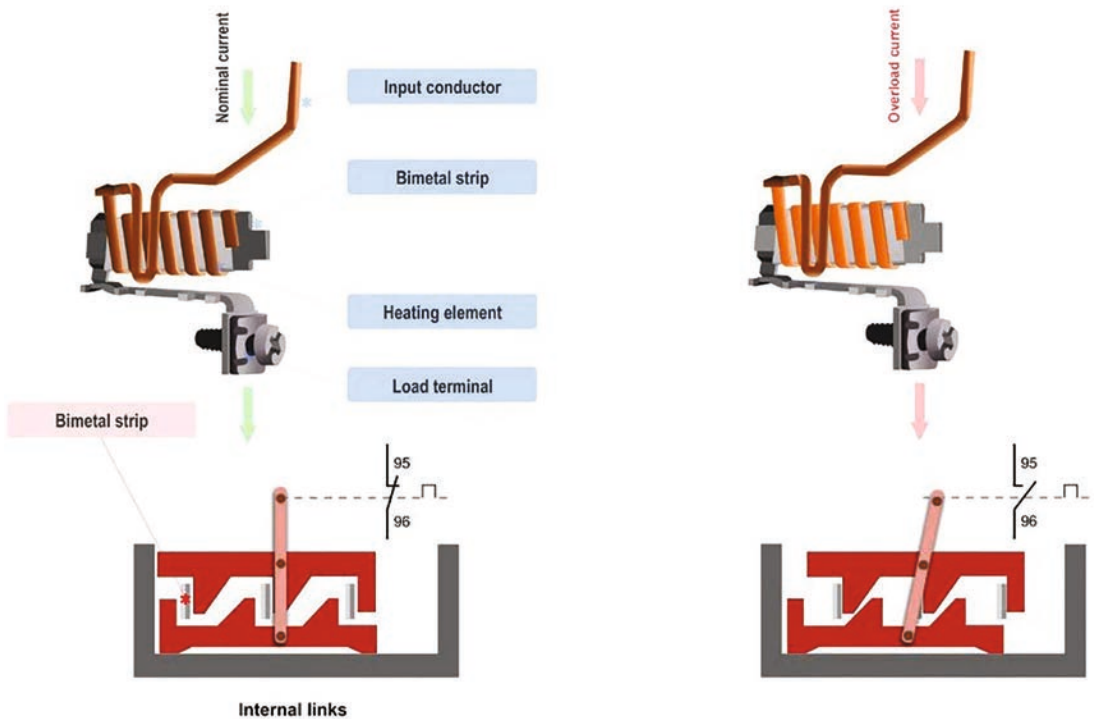

Figure 1.27 – Overload relay operating principles

Figure 1.27 illustrates how the overload relay operates. Under the motor's normal operating conditions (illustrated on the left of the figure), the heat generated by the heater element will not be sufficient to bend the bi-metallic strip, so there will be no tripping of the auxiliary contact.

Under overload conditions (illustrated on the right of the figure), the heater element will increase heat output. This causes the bi-metallic strip to bend until the trip mechanism is tripped and auxiliary contact 95/96 is opened. On opening contact 95/96, the phase power to the motor will be turned off through a control circuit, preventing any further damage of the winding. When a trip occurs, the normally open contact 97/98 will close. This state change can be used to activate various alarm circuits as a trip monitor if this is required by register regulations.



If the overload relay is tripped while the contacts are latched, the problem that caused the overload should be resolved before resetting the starter.

Some thermal overload relays, equipped with a bi-metallic strip, are designed so that the relay will reset automatically if preset to do so. In Figure 1.28,

Trip class 10 is the most common trip class for onboard installations, but there are also use cases for classes 5, 20, 30, 40 and 45.

A class 10 overload relay must trip the motor off-line in 10 seconds or less when the current is more than 7.2 times higher than the nominal current. After starting, this should be enough time for the motor to reach its full speed.

As the characteristics of the trip class illustrate, there should be no tripping around $1.05 \times I_e$, but if the current becomes $1.15 \times I_e$, the relay will trip.



It is important to remember that an overload relay will not protect a motor from a short circuit. If there is a short circuit on the load side of a relay and the backup fuse or the motor starter protectors are rated too highly, the relay's thermo elements will be damaged beyond use.

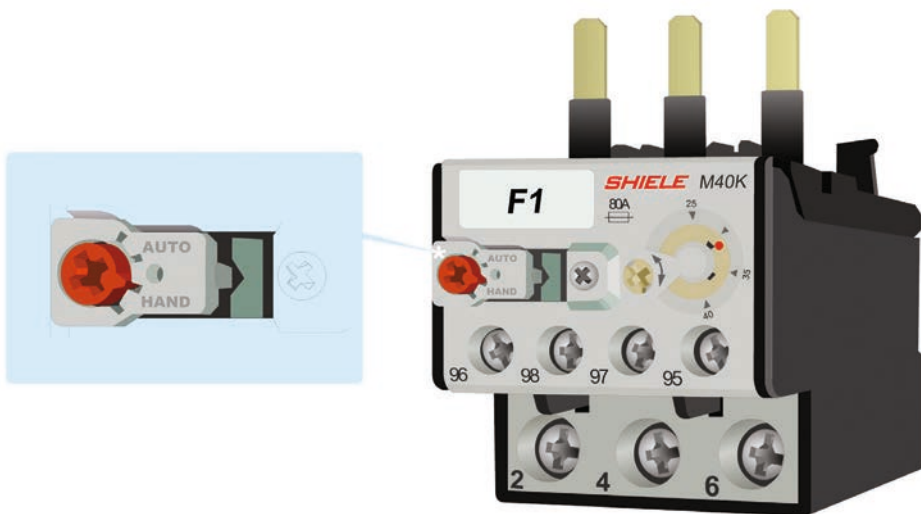

Figure 1.28 – Thermal overload relay, reset after trip

the reset operation can be either 'auto' or 'hand'. The hand reset position must always be used when continuous contact devices are used in the control circuit, eg pressure and level switches. This is to prevent automatic restarting. If the circuit trip was due to an overload caused by one of the continuous devices, any automatic restart would cause an overload-trip-overload cycle.

Trip Class

Overload relays are rated by trip class. This is defined by measuring, in seconds, the length of time that it takes for an overload relay at a specific current to trip. Usually, this is defined as 7.2 times the continuous current rating.

Trip class identifies the different tripping characteristics for various motor starting conditions. This ranges from normal to heavy starting.

Minimum trip current may vary from the trip current rating value (which is regularly set to the e-motor's FLA – Full Load Current), since ratings are established under standardised test conditions. Factors that influence variations include enclosure size, proximity to heat-producing devices and ambient temperature. Except for ambient temperature-compensated overload relays, an ambient temperature higher than 40°C would lower the trip current, and a lower temperature would increase it. This variation can become a factor in setting the OCR if the ship's trade area is tropical. In such cases, if trips occur due to ambient temperature, a correction factor should be used to readjust the FLA setting. The ambient temperature compensation curve is illustrated in Figure 1.29b. The approximate trip current for a particular ambient temperature is a product of the multiplier corresponding to the temperature and the 40°C trip current rating.

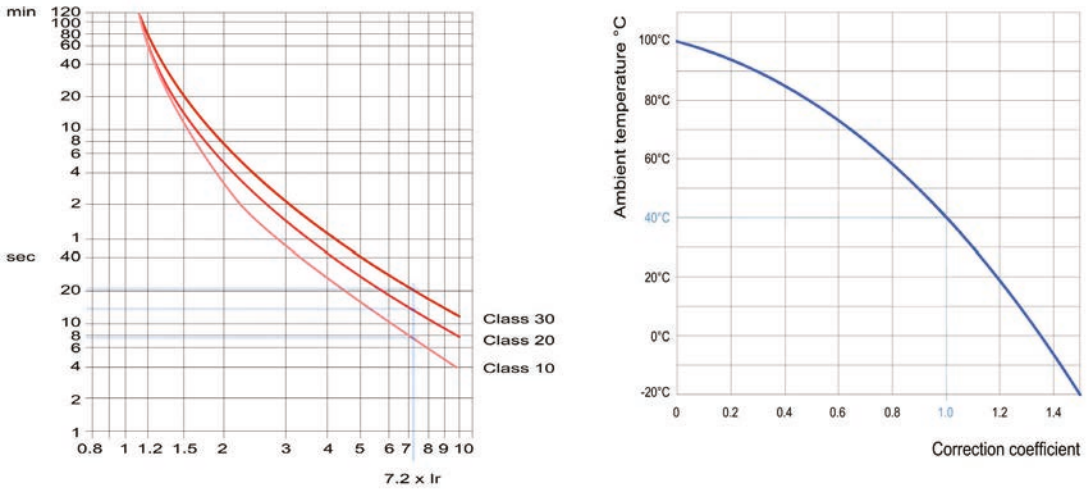

Figure 1.29 – a) Thermal overload relay trip class characteristic; b) Ambient temperature compensation characteristic



Setting starter feeder protection									
  3 ~ Motors 50/60 Hz  Fuses	220 V	380 V	415 V	440 V	500 V	660 V	1000 V	Class 10	Class 20
	kW	kW	kW	kW	kW	kW	kW	Amp	Amp
30...50	9	15	18,5	18,5	22		45	50	80
	11	22	22	22	30		55		
48...80	15	30	30	30	37	45	75	80	100
	18,5	37	45	45	55	55	90		
	22	45	55	55	75	110	110		
60...100	18,5	30	37	37	45	55	90	100	125
	22	37	45	45	55	75	110		
		45	55	55	75	90	132		
90...150	30	55	55	55	75	110	132	160	200
	37	75	75	90	90	132	160		
	45	75	75	90	90	132	200		
132...220	45	75	75	90	110	132	200	250	315
	55	90	90	110	132	160	250		
		110	110	132	160	200	280		
200...330	75	110	110	132	160	200	250	400	400
		132	132	160	200	220	280		
		160	160	200	220	250	315		
	90						400		
300...500	110	160	200	200	220	315	450	500	630
		200	220	220	250	355	500		
		220	250	250	315	400	560		
		250	250	250	355	400	630		
	132						710		
380...630	132	220	220	250	315	400	560	630	800
		250	250	315	355	500	630		
		280	315	355	355	560	710		
		315	355	400	400	560	800		
	160						900		

Figure 1.30 – Setting motor starter feeder protection

Figure 1.30 represents an example of setting motor starter feeder protection by means of thermal overload relay and fuses as a ratio with a motor full load current.

1.1.6 Motor Starter Protectors

Motor starter protectors (MSP), also known as motor circuit breakers, incorporate class 10 or class 20 bi-metallic overload relays as well as a magnetic trip

element for short circuit protection. This protects smaller 3-phase motors from an overload and short circuit.

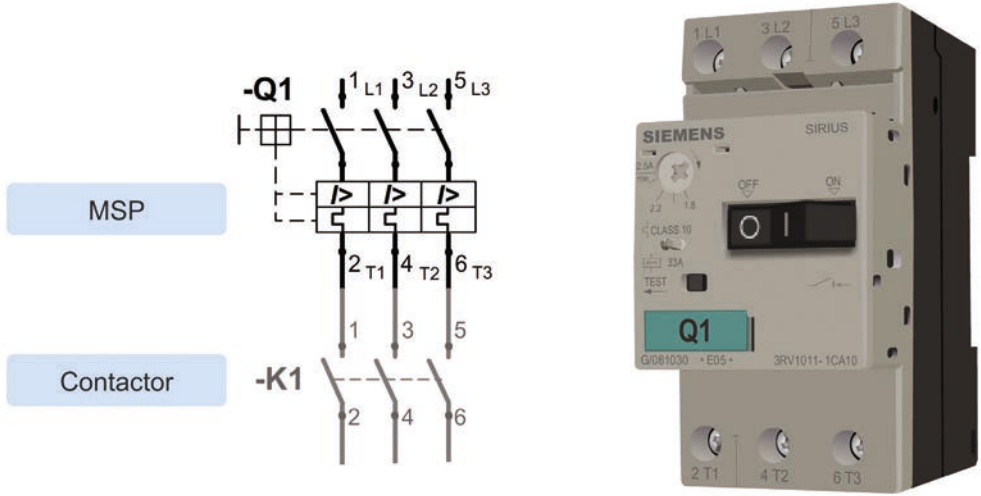

Figure 1.31 – Motor starter protector

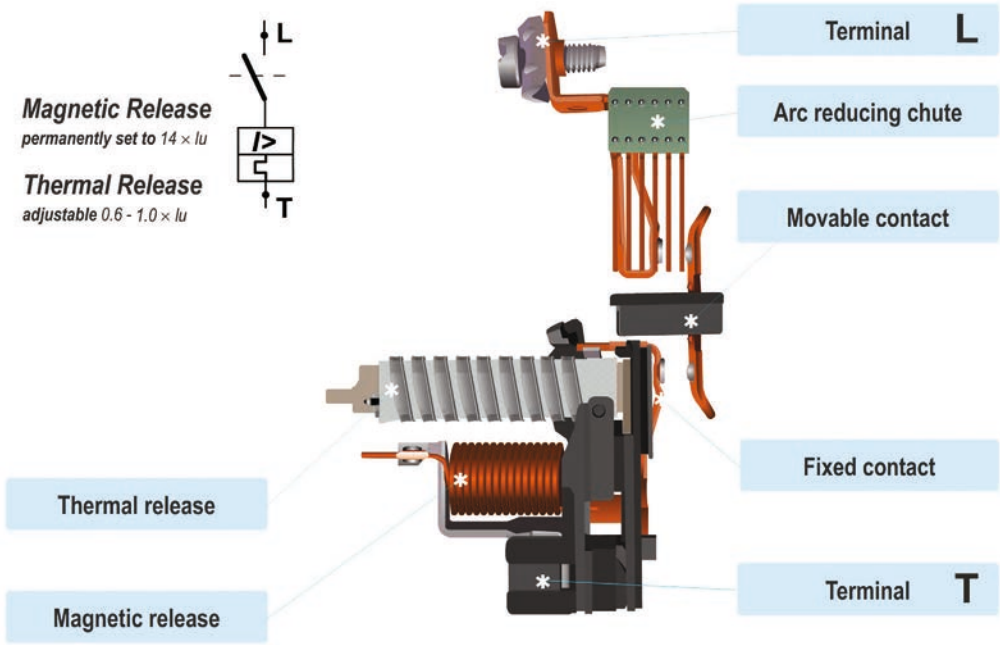

Figure 1.32 – Motor starter protector, internal components layout

Motor starter protectors operate on a current limiting principle. The thermal trip action is achieved by using a bi-metallic element that is heated by the load current.

An instantaneous magnetic release is used to achieve the short circuit action.

When a fault causes a short circuit, the shorting current will cause the electromagnet to attract the associated armature. The moving armature unlatches the trip mechanism, tripping all three poles of the breaker.

This trip action occurs very quickly (approximately 20 milliseconds), the only delay being the time that it takes for the contacts to physically open.



The thermal overload and instantaneous magnetic releases will trip the breakers of all three poles in a 3-phase system. This tripping cannot be prevented by the latch position being forced as the breakers have a trip free mechanism.

1.1.7 Motor Starter Protector Accessories

Motor starter protectors can be integrated with different modules:

Lateral auxiliary contacts module

When the status of a motor starter protector, whether it is open, closed or tripped, is to be monitored, eg by using an alarm system, the normally open/normally closed lateral contacts module is used.

Trip indicating contact module

When it is important that the type of trip is known, a trip indicating auxiliary contact should be used. This contact indicates the causing actions, such as general trip, trip by voltage release overload release or short circuit release.

Early make contact module

A side mounted early make contact module may also feature in the control diagrams. The working principle of these contacts is similar to the control relay early make contacts. When a motor starter protector is switched on, the early make contacts will close before the main contacts of the motor starter protector. These early make contacts are used for interlock and load shedding circuits, as well as early make switching of the undervoltage release with the main switch and/or emergency stop applications.

Undervoltage release module

An undervoltage release module allows the motor starter protector to be controlled remotely by tripping the latching mechanism when the supply voltage drops significantly. This module prevents the motor starter from restarting automatically once it has been tripped, as it is impossible to reset the motor starter protector and restart the motor unless the release coil has been re-energised.

Shunt release module

A shunt release allows the motor protector to switch off immediately as soon as the coil is connected to the supply voltage.

Only one out of these two releases is used for a single motor starter protector.

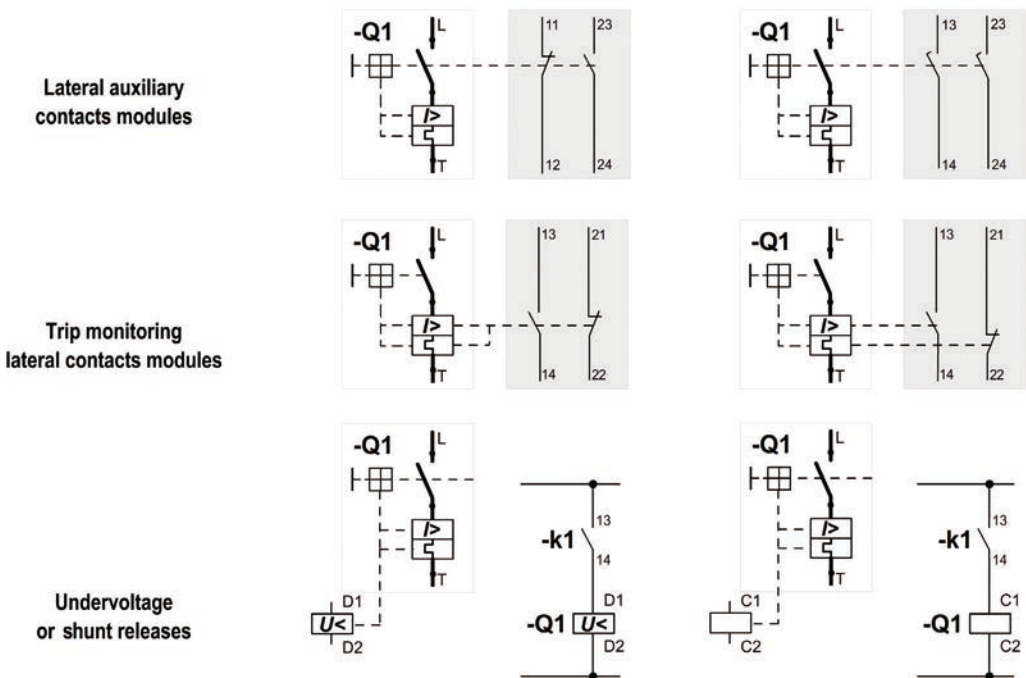

Figure 1.33 – MSP accessories